

SteadyStand®

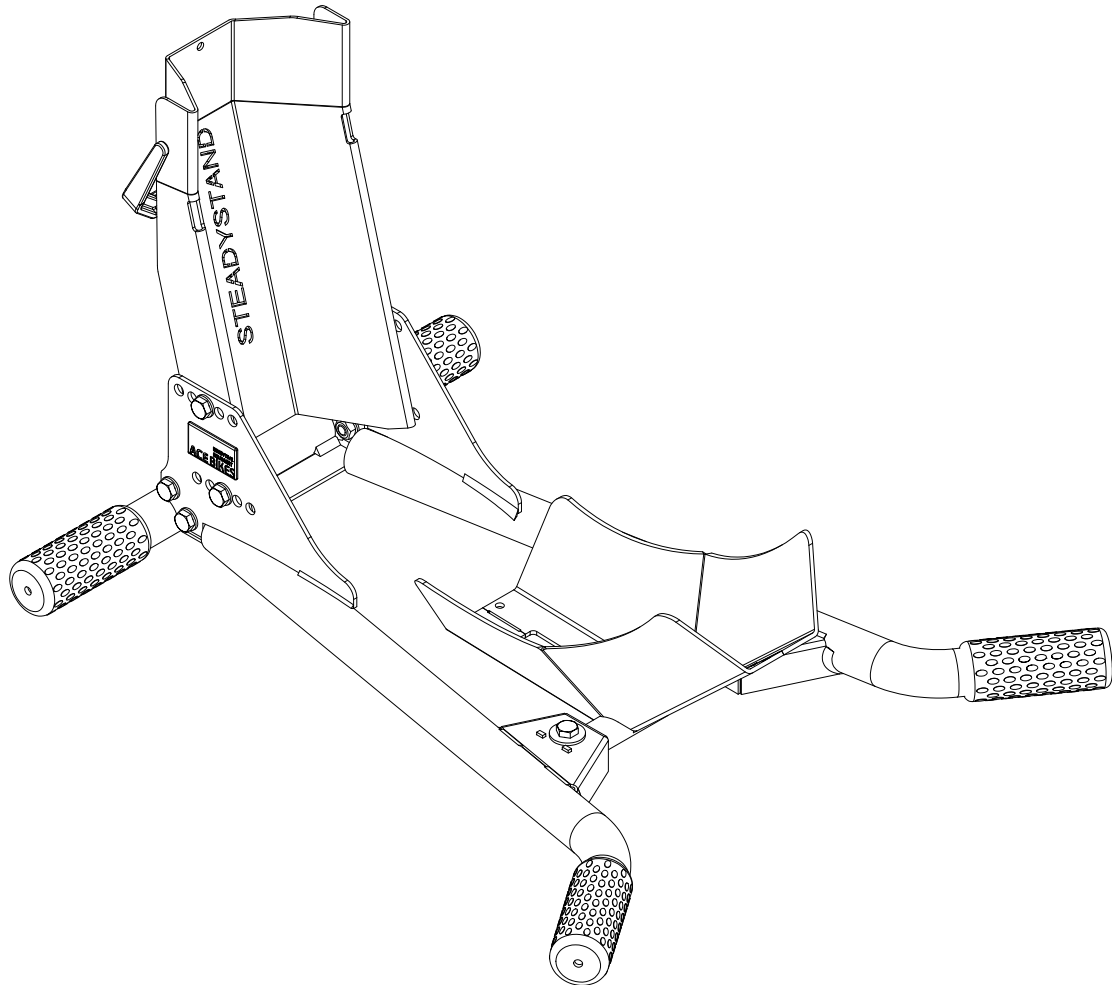

ENG: Please understand, that AceBikes cannot be held responsible for any consequential loss or damage due to an improper assembly or use of the product.

DE: Bitte, haben Sie Verständnis dafür, dass AceBikes keine Haftung für Folgeschaden übernimmt, die durch eine unsachgemäße beziehungsweise mangelhafte Montage entstehen.

FR: Veuillez comprendre que AceBikes ne peut être tenu pour responsable des dommages consécutifs à un montage ou une utilisation incorrecte.

Netto weight : 7,2 kg
 Box size: 60x22x20 cm
 Rim size 15-19" / 90-130 wide

Designed in The Netherlands

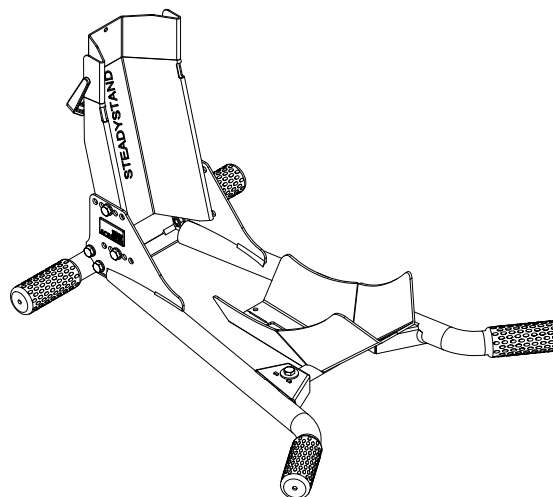

ACEBIKES

Handelsstraat 19 NL-7772 TS
 Hardenberg
 The Netherlands
 T +31 (0)523-745060
 E info@acebikes.nl
 I www.acebikes.com

Deutsch

Montageanleitung für Vorderradständer

Allgemeine Hinweise

Bitte, lesen Sie vor Montage und ersten Gebrauch die Montageanleitung aufmerksam durch. Bitte, haben Sie Verständnis dafür, dass Ace Bikes keine Haftung für Folgeschaden übernimmt, die durch eine unsachgemäße beziehungsweise mangelhafte Montage entstehen. Warnung: Es ist unter Umständen nicht vermeidbar, dass der Reifen leicht im Ständer "klebt". Wir empfehlen, den Reifen ggf. vor dem Herausfahren durch leichte Seitwärtsbewegungen zu lösen.

English

Assembly instruction for Front Wheel Stand

General advice

Please have a careful look at this assembly instruction before assembling and applying the product. Please understand, that AceBikes cannot be held responsible for any consequential loss or damage due to an improper assembly or use of the product. Warning: Under certain circumstances it is unavoidable, that the tire adheres slightly to the paddock stand. We recommend to loosen the tire by slight sideways movements before pulling out the motorcycle.

Français

Manuel d'installation pour Béquille avant

Informations générales

Avant le montage et l'utilisation du produit, veuillez regarder soigneusement ce manuel d'installation. Veuillez comprendre que AceBikes ne peut être tenu pour responsable des dommages consécutifs à un montage ou une utilisation incorrecte. Avertissement: Dans certains cas il est inévitable que le pneu adhère légèrement à la béquille. Nous recommandons de décoller le pneu par mouvements légers sur le côté avant de sortir de la béquille.

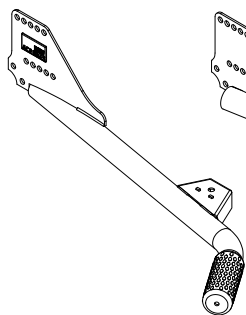

1x

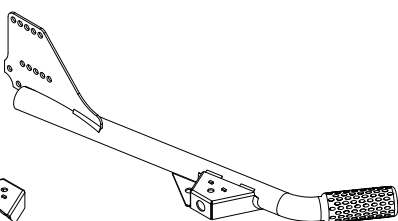

1x

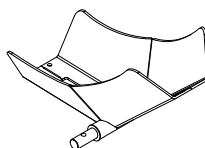

1x

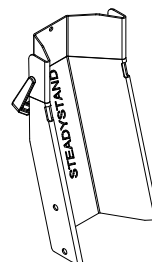

1x

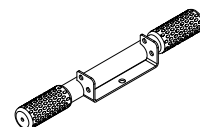

1x



8x



16x

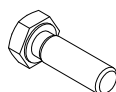

2x



8x

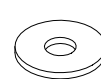

2x

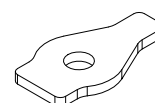

1x

1

DE Handfest anziehen UK Hand tightened only FR Serrez à la main

1x

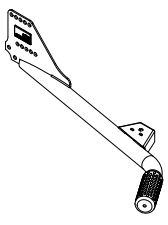

1x

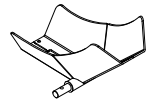

1x



1x

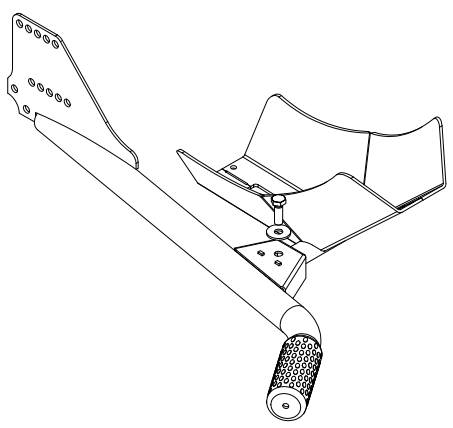

2

DE Handfest anziehen UK Hand tightened only FR Serrez à la main

1x

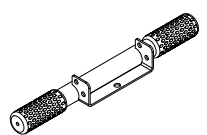

2x



4x



2x

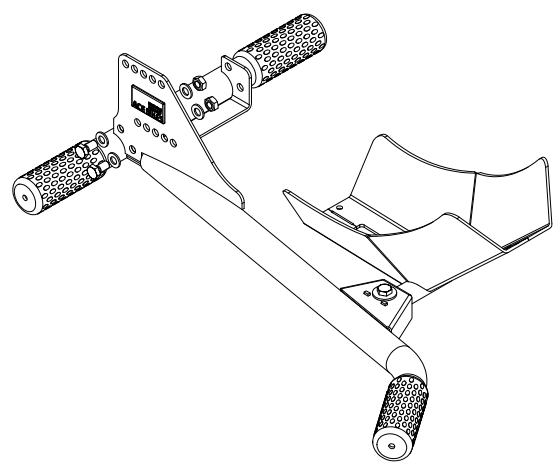

3

DE Handfest anziehen UK Hand tightened only FR Serrez à la main

1x

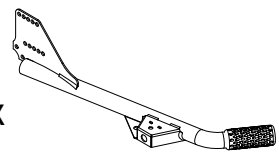

2x



4x



2x



1x



1x



1x

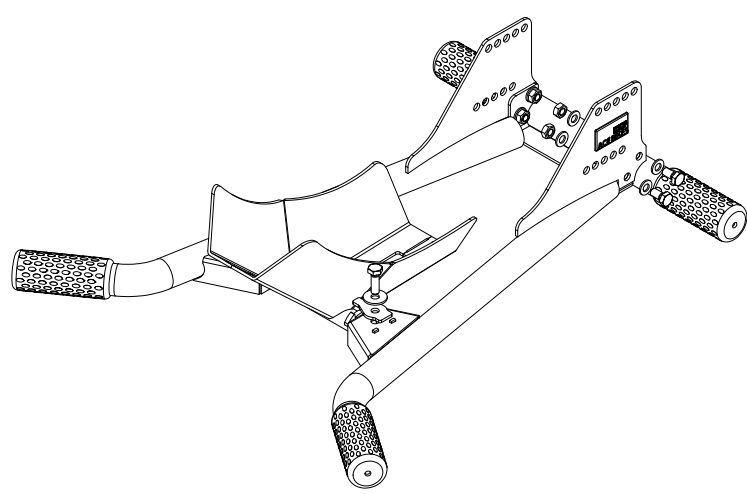

DE Handfest anziehen **UK** Hand tightened only **FR** Serrez à la main

4

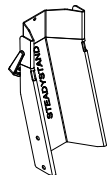

1x

4x



8x



4x

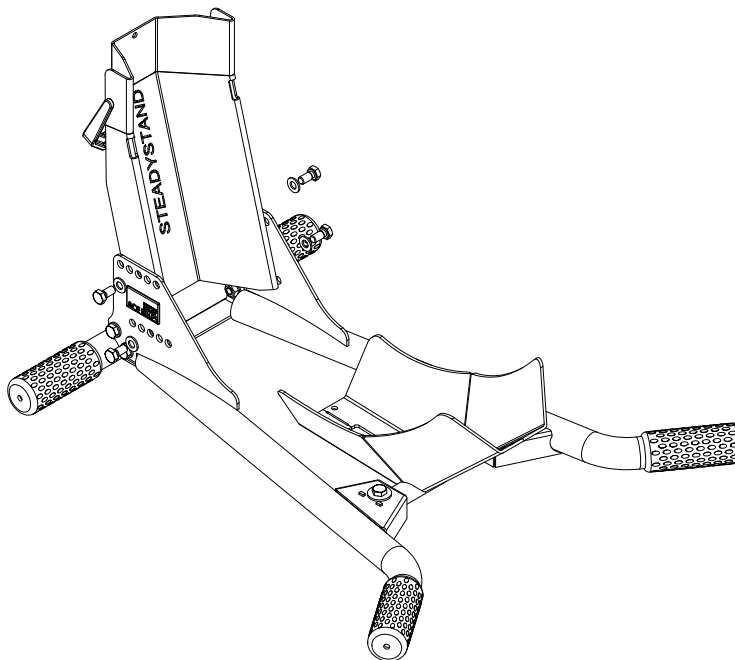

5

D Anziehen in dieser Reihenfolge auf einer ebenen Oberfläche

UK Tightening in this order on flat surface

FR Serrage dans cet ordre sur une surface plane

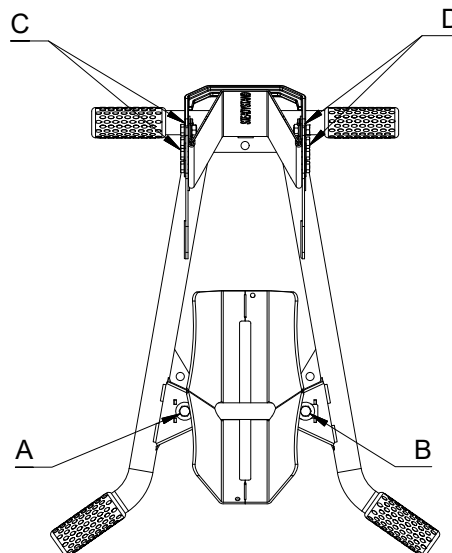

DE Einstellung **UK** Adjustment **FR** Ajustement

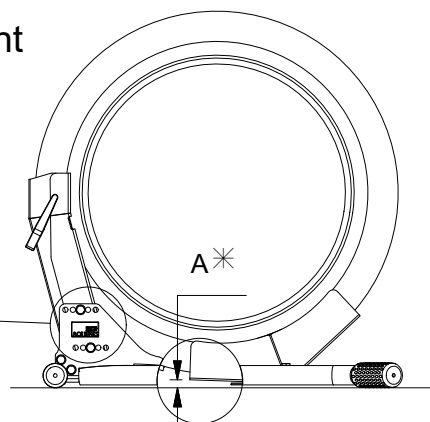
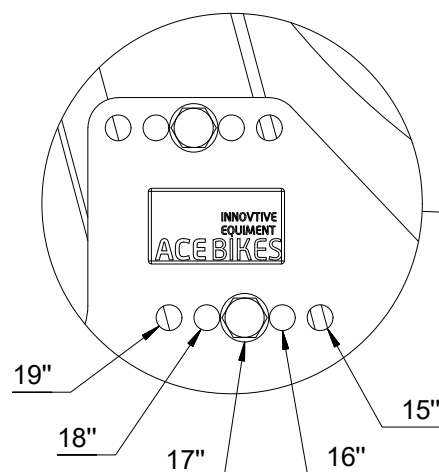

A* Raum zwischen dem Behälter und dem Boden für ein richtigen Einstellung.
Bemerkung Wenn kein Spielraum, Pos. 8 eine Stufe kleiner einstellen

A* Space between the support and the ground for a proper adjustment
Remark With no space, set pos. 8 a step smaller

A* il doit y avoir un espace entre le support et le sol pour un bon réglage
Remarque si il n'y a pas de jeu, positionner pos.8 sur un cran de moins

Parts list **SteadyStand**®

Item	Qty	Description
1	2	Bearing
2	2	M8 x 25
3	2	Washer large
4	1	Frame R
5	1	Frame L
6	1	Frame back
7	4	Grip
8	1	Wheel support front
9	8	Nut M8
10	16	Washer
11	8	M8 x 16
12	2	Sticker
13	1	Handle
14	1	Wheel support
15	1	Shaft 15
16	1	Plate

